

# GCprofile Therm

## Profile system fanlight

EN Pre-installation and  
installation instructions

187227-00

## Contents

1	Introduction.....	4
1.1	Symbols and illustrations .....	4
1.2	Revisions and validity.....	4
1.3	Product liability .....	4
1.4	Reference documents.....	4
1.5	Abbreviations.....	4
2	Fundamental safety precautions .....	5
2.1	Intended use.....	5
2.2	Safety notices.....	5
2.3	Safety-conscious working .....	5
2.4	Environmentally conscious working.....	5
2.5	Connection to the structure.....	6
2.6	Safety instructions related to transportation and storage .....	6
2.7	Qualification .....	6
3	About this document.....	7
3.1	Overview.....	7
3.1.1	Divided fanlight .....	7
3.1.2	Non-divided fanlight.....	7
4	Overview.....	8
4.1	Diagrams.....	8
4.2	Tools and aids.....	8
4.3	Torques.....	8
4.4	Consumables.....	8
5	Scope of delivery and completeness.....	9
6	Pre-installation in the workshop.....	9
6.1	Installing the fanlight frame.....	9
6.1.1	Preparations .....	9
6.1.2	Attaching butt connectors (only with divided fanlight).....	9
6.1.3	Coating the profile ends with sealing mass.....	10
6.1.4	Sliding the corner brackets in place .....	11
6.1.5	Joining the frame parts .....	12
6.1.6	Aligning and fixing the frame corners.....	13
6.1.7	Driving in grooved pins.....	13
6.1.8	Gluing the profiles.....	14
6.1.9	Inserting reinforcement brackets.....	15
6.1.10	Sealing the reinforcement brackets .....	15
6.2	Preparing glazing .....	16
6.2.1	Cut the glass strips to size .....	16
6.2.2	Inserting glass bridges.....	17
6.2.3	Drawing in the outer glazing profile.....	18
6.2.4	Inserting glass strips .....	19
6.2.5	Final work.....	19

7	Installation on site .....	20
7.1	Removing the glass strips.....	20
7.2	Preparing the girder section .....	20
7.3	Fixing the fanlight in place.....	20
7.3.1	Inserting the draining caps.....	21
7.3.2	Inserting glass.....	21
7.4	Final work.....	21
7.5	Replacing glass panes.....	22
8	Cleaning.....	22
9	Disassembly.....	22



# 1 Introduction

## 1.1 Symbols and illustrations

### Warning notices



Warning notices are used in these instructions to warn you of property damage and personal injury.

- ▶ Always read and observe these warning notices.
- ▶ Observe all measures marked with the warning symbol and warning word .

Warning symbol	Warning word	Meaning
	<b>WARNING</b>	Danger to persons. Non-compliance can result in death or serious injuries.
	<b>CAUTION</b>	Danger to persons. Non-compliance may lead to minor injuries.

### More symbols and illustrations

Important information and technical notes are highlighted to explain correct operation.

Symbol	Meaning
	means "important information"; Information on avoiding material damage, understanding a concept or optimising the operation sequences
	means "additional Information"
▶	Symbol for an action: This means you have to do something. ▶ If there are several actions to be taken, keep to the given order.

## 1.2 Revisions and validity

Version 00: Valid for GCprofiles Therm with drive ECdrive T2 and ECdrive T2-FR from model year 2019

## 1.3 Product liability

In compliance with the liability of the manufacturer for his products as defined in the German "Product Liability Act", compliance with the information contained in this brochure (product information and intended use, misuse, product performance, product maintenance, obligations to provide information and instructions) must be ensured. Failure to comply releases the manufacturer from his statutory liability.

## 1.4 Reference documents

Type	Name
Processing documents	Profile overview
Manufacturing documents	<ul style="list-style-type: none"> <li>▫ Order-related manufacturing parts list</li> <li>▫ Machining drawings</li> </ul>
System overview	GCprofile Therm fanlight and accessories
Installation instructions	GCprofile system leaves and side panel
Installation instructions	GCprofile Therm
Installation instructions	Sliding door system

The diagrams are subject to change without notice. Use only the most recent version.

## 1.5 Abbreviations

HSK	Main closing edge
NSK	Secondary closing edge
OKFF	Finished floor level
DH	Passage height

## 2 Fundamental safety precautions

### 2.1 Intended use

The sliding door system is used for the automatic opening and closing of a building passage.

The sliding door system may only be used in a vertical installation position and in dry rooms within the permitted application area (see installation and service instructions).

The sliding door system is designed for pedestrian traffic in buildings.

The sliding door system is not designed for the following uses:

- for industrial use
- for areas of application which do not serve pedestrian traffic (such as garage doors)
- on mobile objects such as ships

The sliding door system may only be used:

- in the modes of operation provided for by GEZE
- with the components approved / released by GEZE
- with the software delivered by GEZE
- in the installation variants / types of installation documented by GEZE
- within the tested/approved area of application (climate / temperature / IP rating)

Any other use is considered non-intended and will lead to the exclusion of all liability and warranty claims to GEZE.

### 2.2 Safety notices

- The mandatory installation, maintenance and repair work must be performed by properly trained personnel authorised by GEZE.
- The country-specific laws and regulations are to be observed during safety-related tests.
- If unauthorised changes are made to the system, GEZE cannot be held liable in any way whatsoever for any resulting damage, and the approval for use in escape and rescue routes ceases.
- GEZE does not accept any warranty for combinations with third-party products.
- Furthermore, only original GEZE parts may be used for repair and maintenance work.
- In compliance with Machinery Directive 2006/42/EC, a risk analysis must be performed and the door system identified in accordance with CE Marking Directive 93/68/EEC before the door system is commissioned.
- Observe the current status of directives, standards and country-specific regulations, especially:
  - DIN 18650: 2010-06 "Building hardware– Powered pedestrian doors"
  - VDE 0100, Part 610: 2004-04 "Installing Electrical Power Systems with Nominal Voltages up to 1000 V"
  - DIN EN 16005: 2013-01 "Power operated pedestrian doorsets; safety in use; Requirements and test methods"
  - DIN EN 60335-1: 2012-10 "Safety of electrical devices for home use and similar purposes - Part 1: General requirements (IEC 60335-1: 2010, modified), German version EN 60335-1: 2012
  - DIN EN 60335-2-103: 2016-05 "Safety of electrical devices for home use and similar purposes - Part 2-103: Special requirements for drives for gates, doors and windows. (IEC 60335-2-103: 2006, modified + A1: 2010, modified), German version EN 60335-2-103: 2015



The product should be installed or incorporated in such a way that effortless access to the product is guaranteed during any repairs and/or maintenance, and that any removal costs do not stand out of proportion to the value of the product.

### 2.3 Safety-conscious working

- Secure workplace against unauthorised entry.
- Watch the swivelling range of long system parts.
- Never carry out work with a high safety risk (e.g. installing the drive, cover or door leaf) while alone.
- Attach safety stickers to glass door leaves.
- Danger of injury caused by unsecured crushing, impact, drawing-in or shearing spots!
- Danger of injury due to broken glass!
- Danger of injury due to sharp edges in the drive!
- Danger of injury during installation through freely moving parts!

### 2.4 Environmentally conscious working

- When disposing of the profile system, separate the different materials and have them recycled.

## 2.5 Connection to the structure

Connection to the structure is to be carried out in accordance with the current version of the "Guide for planning and carrying out installation of windows and front doors in new and refurbished buildings" issued by the RAL-Gütegemeinschaft Fenster und Haustüren e. V. (*RAL Quality Institute for Windows and Doors*).

## 2.6 Safety instructions related to transportation and storage

- ▶ Do not throw, do not drop.
- ▶ Avoid strong blows.
  - Storage temperatures under -30 °C and above +60 °C can result in damage to the device.
  - Protect against humidity.
- ▶ Use special glass transport devices (e.g. A-frames) for transporting glass.
- ▶ Separate several panels on a frame or during storage using intermediate layers (e.g. cork pads, paper or plastic cords).
- ▶ Always store glass in a vertical position on level and load-bearing ground. Use suitable material as a support (e.g. wooden slats).
- ▶ In the case of insulated glass, make sure that it is placed flush across the entire element thickness on at least 2 supports.
  - During storage and support, safety devices must not cause any damage to the glass or edge seal of insulated glass and must be attached flat on the pane surface.
  - Dry, well ventilated, closed, weather-proof and UV-protected rooms are suitable as storage areas.

## 2.7 Qualification

Pre-installation of the GEZE sliding door drive may only be carried out by companies which have been approved by the testing institute (TÜV Thüringen) as an extended manufacturing facility.

### 3 About this document

#### 3.1 Overview

These instructions describe installation of the profile system fanlight for an automatic sliding door system. Pre-installation and installation of the divided and non-divided fanlight are described.

##### 3.1.1 Divided fanlight

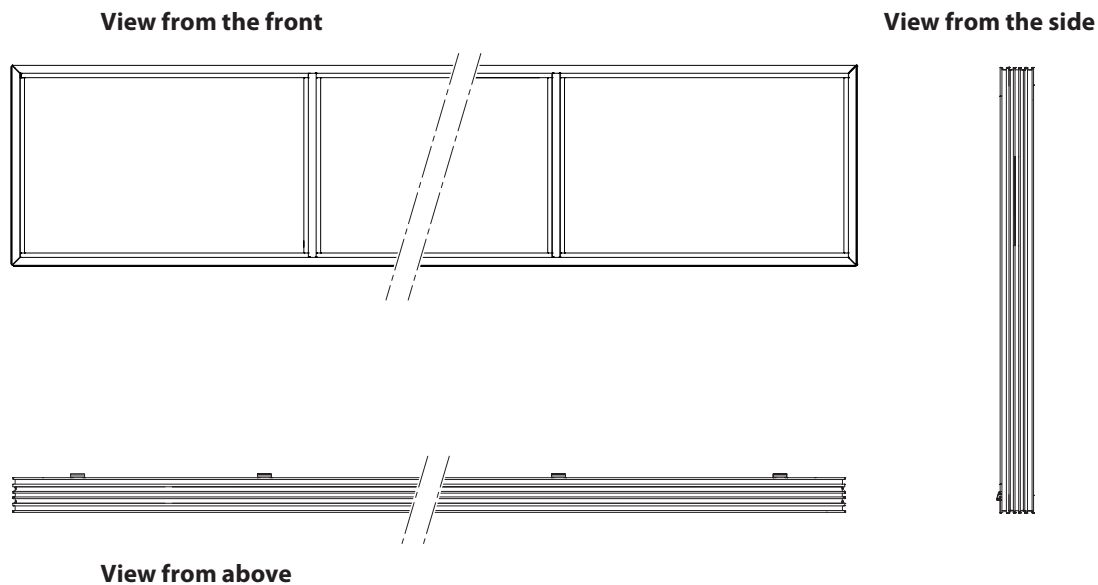

##### 3.1.2 Non-divided fanlight

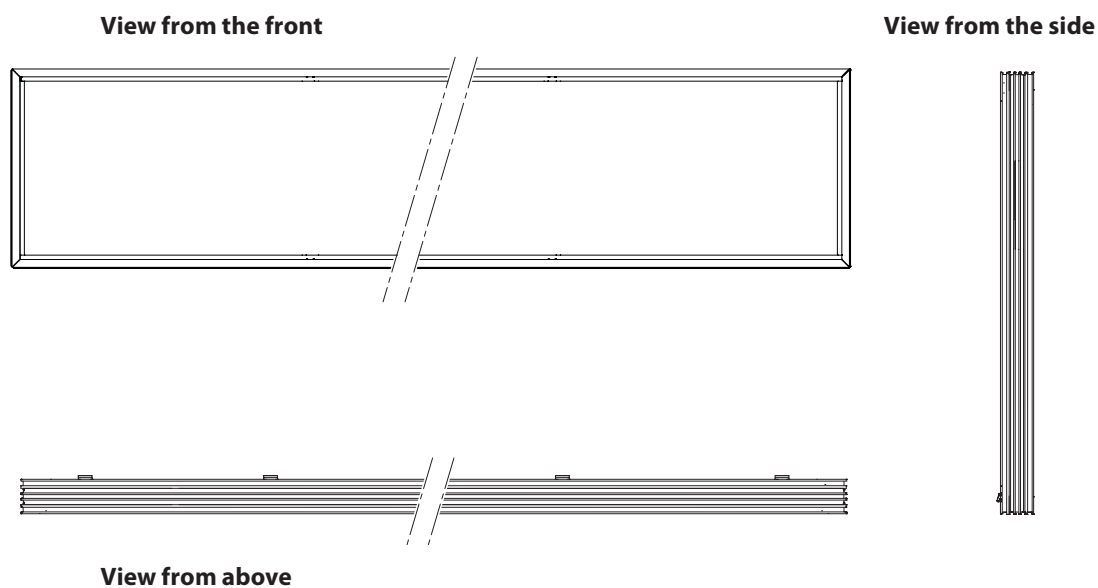

## 4 Overview

### 4.1 Diagrams

Drawing no.	Type	Name
70723-9-0985	Installation instructions	Fanlight, 1-section
70723-9-0986	Installation instructions	Fanlight, 2-section
70723-9-0987	Installation instructions	Fanlight, 3-section

The diagrams are subject to change without notice. Use only the most recent version.

### 4.2 Tools and aids

Tool	Size/number/use
Blade	
Screw clamps and plates	for levelling the profile edging
Trestles	number depending on fanlight to be installed
A-frames	
Tensioning strap	
Vacuum lifting pads	
Spirit level/plumb bob/cross-hair laser	
Tape measure	5 m or 10 m
Engineer steel square 90°	for checking corner brackets
Allen key	3 mm; for fitting the butt connectors
Torx screwdriver	
Side-cutting pliers	
Driving mandrel	for corner and butt connector (mat. no. 181186)
Manual cartridge gun	for sealing compound
Painter's roller	B100-150; for simplified application of the sealing compound
Rubber/plastic hammer	
Pneumatic DUO cartridge gun	for processing the adhesive
Pencil	
Seal cutting shears	HUECK-ID Z 909913
Seal cutting shears for mitre cuts with tapping block	HUECK-ID Z 921123
Auxiliary tool 70723-2-0336	for aligning the muntins if required
Vacuum lifting pads	

### 4.3 Torques

The torques are given with the respective installation step.

### 4.4 Consumables

Consumable	Use/art/mat. no.
Sealing compound, grey	for sealing (mat. no. 167318)
Special cleaner	HUECK-ID Z 912750; for removing sealing compounds and residual adhesive
EPDM adhesive	for sealing glazing seal joints (mat. no. 180280)
Two-component adhesive in DUO cartridges	Mat. no. 167315; for corner connection fanlight
Static mixer	
Glazing blocks	



## 5 Scope of delivery and completeness

- ▶ Open packaging units and check for completeness on the basis of the delivery note.

## 6 Pre-installation in the workshop

### 6.1 Installing the fanlight frame

- ! Make small marks e.g. using a pencil on the decorative surfaces of the profiles. These marks are only very difficult to remove from anodised surfaces.

i The following chapter describes installation of the fanlight frame with muntins for large opening widths (divided fanlight). Installation of the fanlight frame without muntins takes place in a corresponding way.

#### 6.1.1 Preparations

- ▶ Place the fanlight frame profiles on trestles or an assembly table.
- ▶ Use a spirit level to check whether the fanlight frame profiles are lying horizontally.
- ▶ Readjust the trestles if necessary.
- ▶ Punch or mill holes for draining (see machining drawing).

#### 6.1.2 Attaching butt connectors (only with divided fanlight)

- ▶ Mark the positions of the butt connectors (1) on the frame profiles (2) at the top and bottom.
- ▶ Slide the butt connectors (1) at the top and bottom onto the frame profiles (2).

- ! Watch the position of the butt connectors (1). The straight ribbed sides (3) must be facing **inwards**.
- Do not use a spherical-head Allen key when screwing the butt connectors tight.

- ▶ Align the butt connectors using an aid (4) if necessary (optional).
- ▶ Screw the butt connectors in place in such a way that the screw breaks through the aluminium profile.
- ▶ Screw the butt connectors (1) in place.

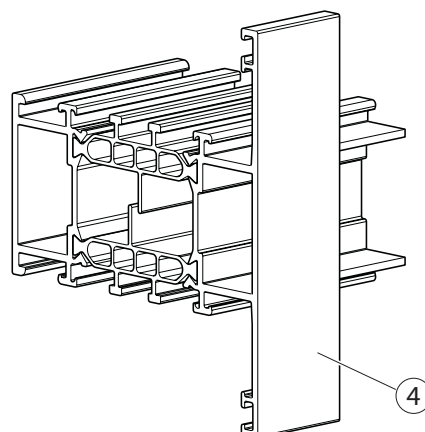
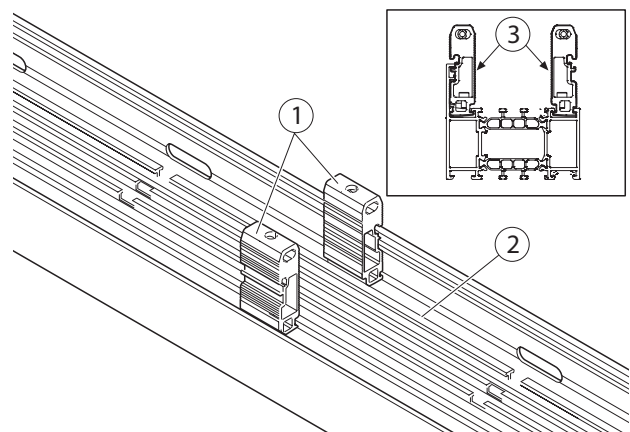

- ▶ Insert the sealing pads (5).

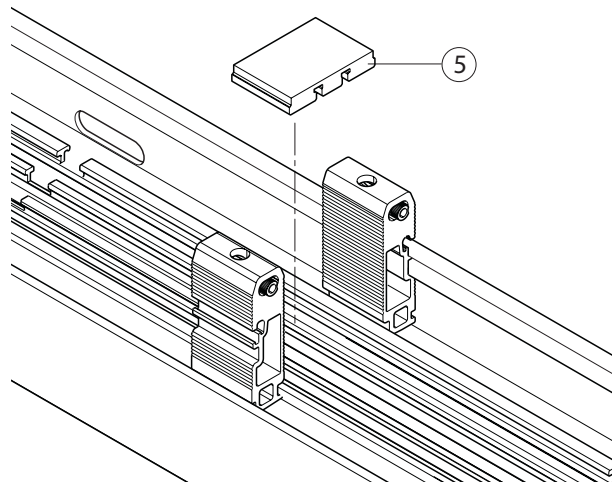

### 6.1.3 Coating the profile ends with sealing mass



- Note the hazard warnings provided by the manufacturer when using the special cleaner and the sealing compound.
- Note the best by date and the processing temperature.
- Wear safety gloves when handling the sealing compound.

- ▶ Clean the profile ends (1) with special cleaner.
- ▶ Apply the sealing compound to the profile ends (1) using the painter's roller or cartridge gun.

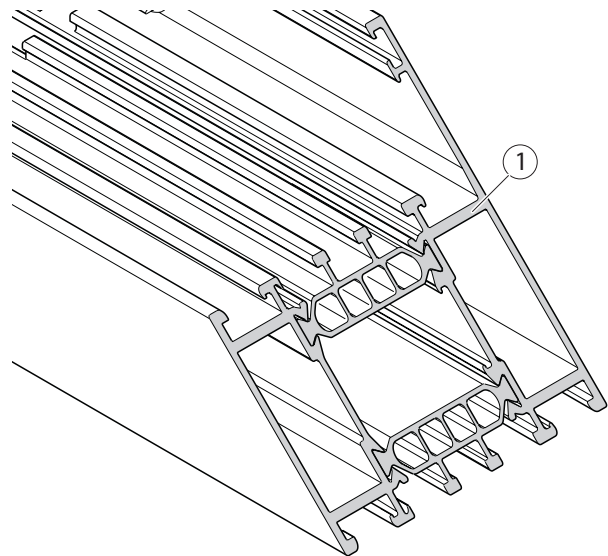

With divided fanlight:

- ▶ Clean the profile ends (1) of the profile bridges using special cleaner.
- ▶ Apply the sealing compound to the profile front sides (1) of the profile bridges using the painter's roller or cartridge gun.

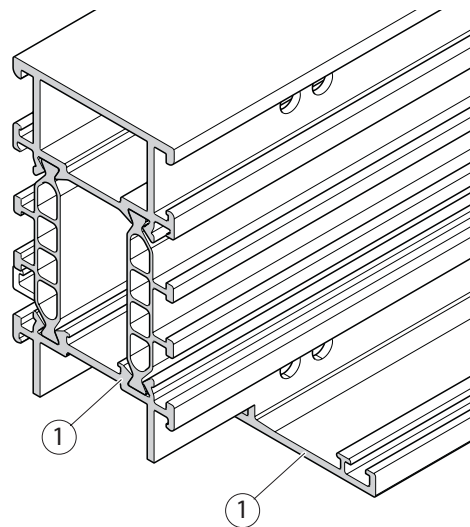

## 6.1.4 Sliding the corner brackets in place

- ▶ Slide the corner brackets (1) into the vertical/short frame profiles on both sides as far as they will go.

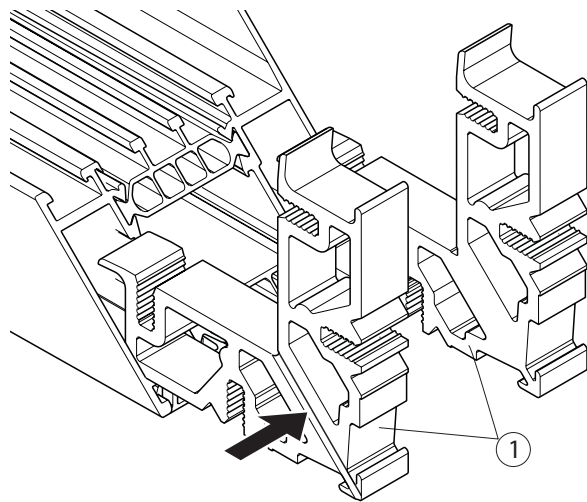

- The grooves in the corner brackets must be facing the outside of the profile (see arrow).

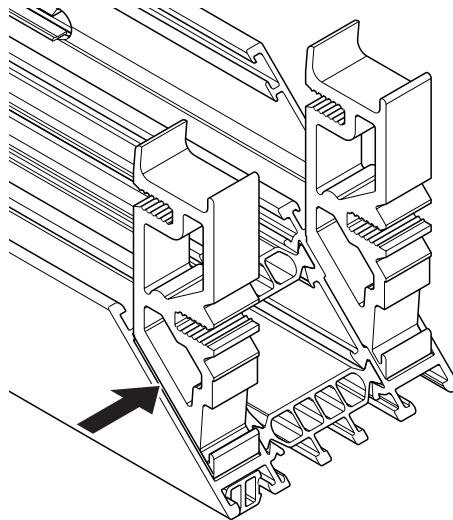

## 6.1.5 Joining the frame parts

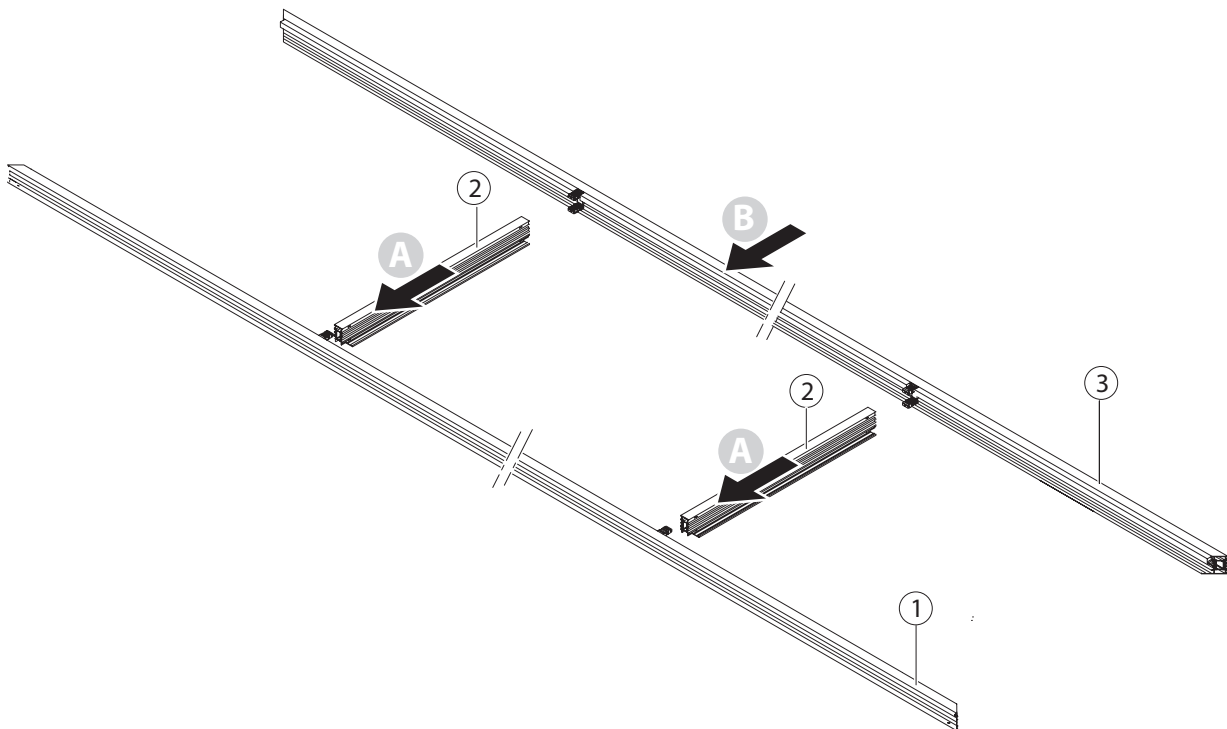
**Divided fanlight**

- ▶ Insert the profile bridges (2) into the long frame section (1) (A).
- ▶ Place the second long frame part (3) on the profile bridges (2) (B).

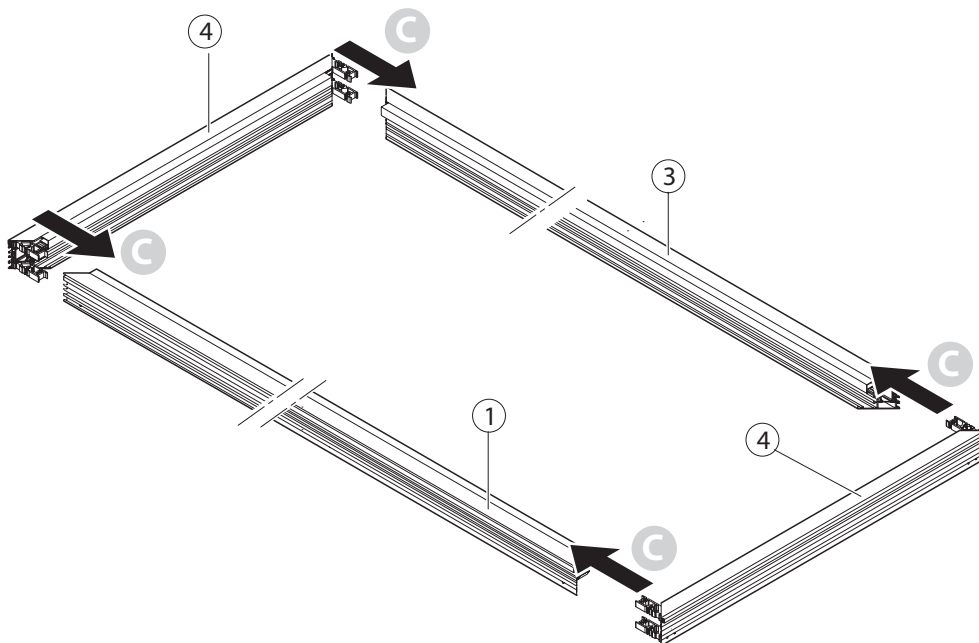

- ▶ Slide the short frame parts (4) onto the long frame parts (1) and (3) (C).

## 6.1.6 Aligning and fixing the frame corners

- ▶ Roughly clean the profile joints using the special cleaner.
- ▶ Align corners with bracket.
- ▶ Fix the frame corners in their precise position using one-handed clamps. Make sure the joint edges are flush.
- ▶ If appropriate, align muntin profile joints using one-handed clamps as well.

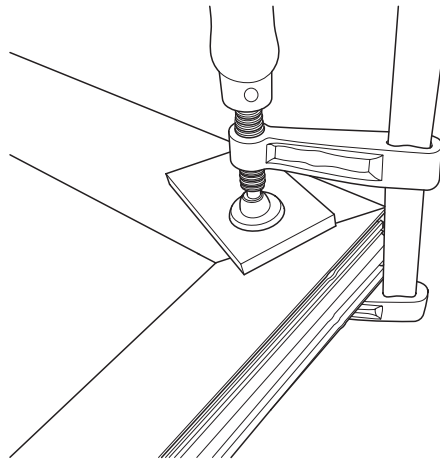

## 6.1.7 Driving in grooved pins

Heed the following when driving the grooved pins in:

- The flattened side of the grooved pin (1) is facing outwards.

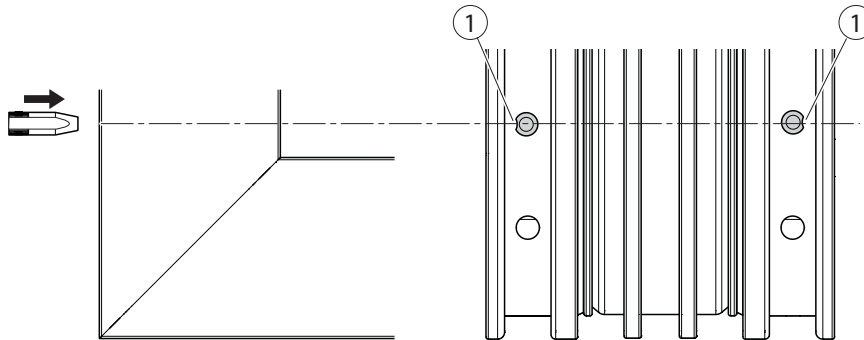

- Choose the inner holes (2) on the horizontal long profiles.
- On the muntins:
  - 4 grooved pins per joint
  - Use the inner holes (3)

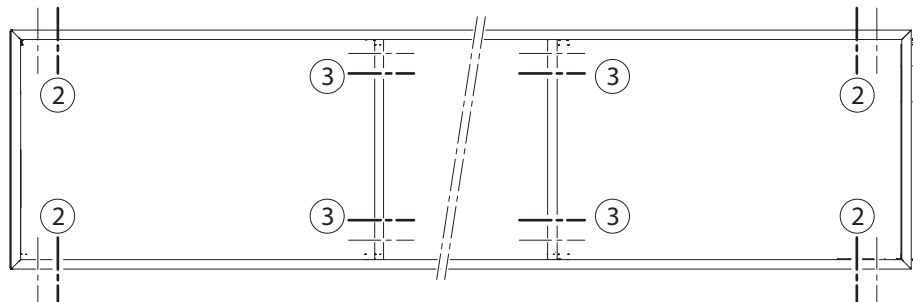

- Drive in the grooved pins that belong to one chamber level directly after one another (sequence A-B and C-D).

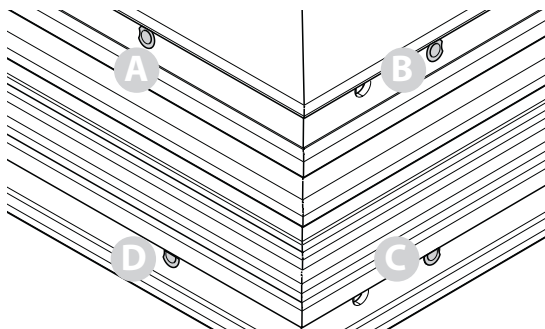

- ▶ Drive the grooved pins (2) into profiles so that they are flush using a hammer and driving mandrel (1).

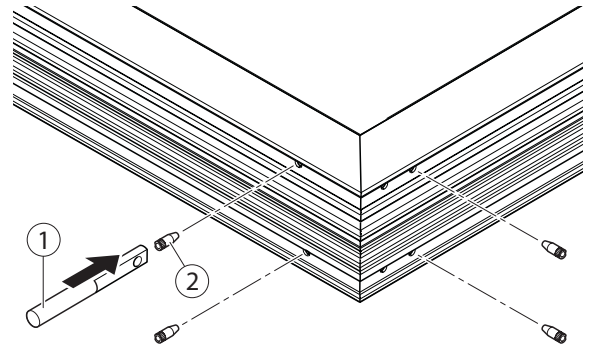

- ▶ Check the alignment of the profile joints.
- ▶ Clean the profile joints thoroughly using special cleaner.

### 6.1.8 Gluing the profiles

The profiles are glued 2x at the frame corners and 4x per joint on the muntins (8x per muntin).

- ▶ Glue profiles using two-component adhesive in pneumatic DUO cartridges.
- ▶ Fill all glue holes with adhesive until the adhesive overflows and exits next to a grooved pin.

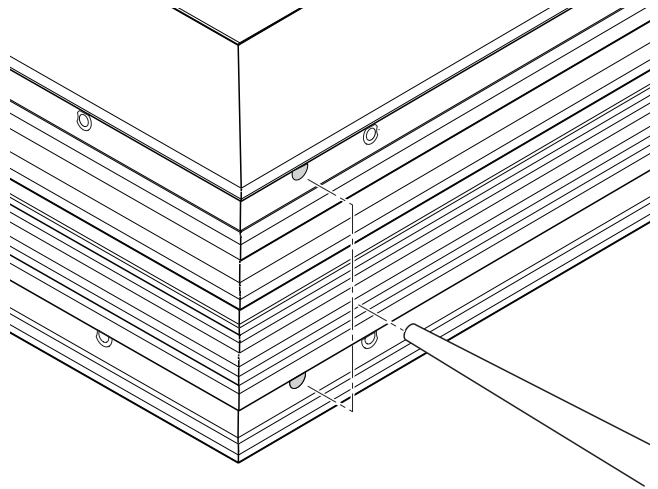

- ▶ Clean the gluing points of the profiles (see arrows) using special cleaner.

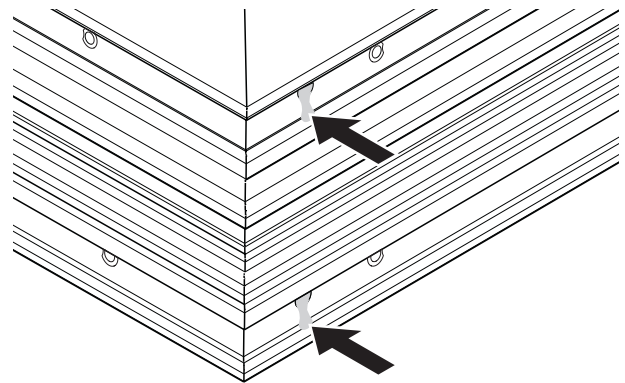

- ▶ Do not move the fanlight frame for about 15 minutes after application of the adhesive.  
Process-related waiting time: 5 h

## 6.1.9 Inserting reinforcement brackets

- ▶ Clip reinforcement brackets (1) to all four corners of the fanlight.

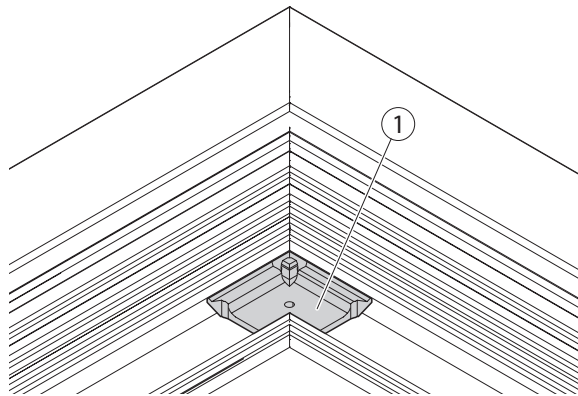
**With divided fanlight**

- ▶ In addition to the reinforcement brackets (1), clip T-reinforcement brackets (3) on the right and left on the muntin profile staves (2) along the side of the muntin profile.

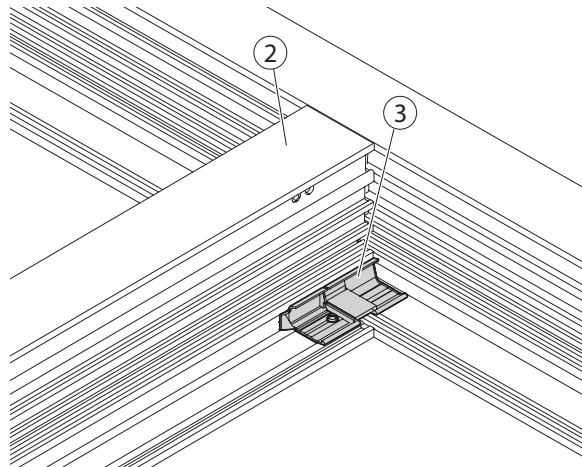

## 6.1.10 Sealing the reinforcement brackets

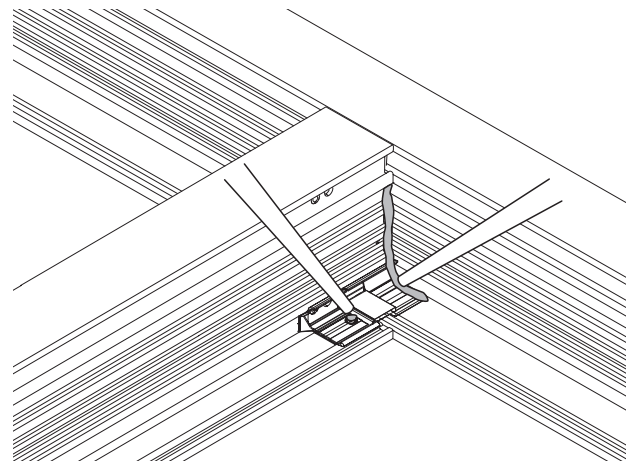
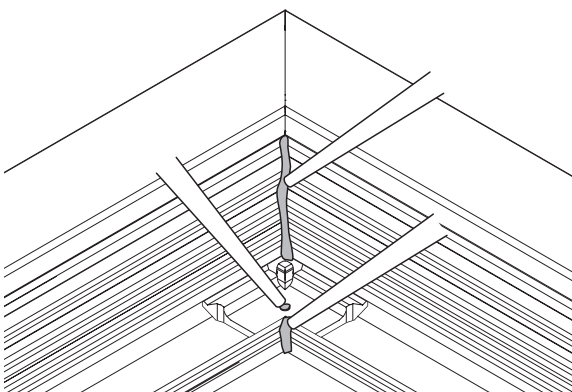

- ▶ Seal all reinforcement brackets, T-reinforcement brackets and frame corners on the inside using sealing compound.
- ▶ Inject sealing compound into the holes on the reinforcement bracket frame edges.
- ▶ Remove sealing compound on the profiles and reinforcement brackets using special cleaner if necessary and wipe down.

## 6.2 Preparing glazing

### 6.2.1 Cut the glass strips to size



- ▶ For painted and powder-coated fanlight use glass strip ID no. 167257.
- ▶ For anodised fanlight use glass strip ID no. 167258.

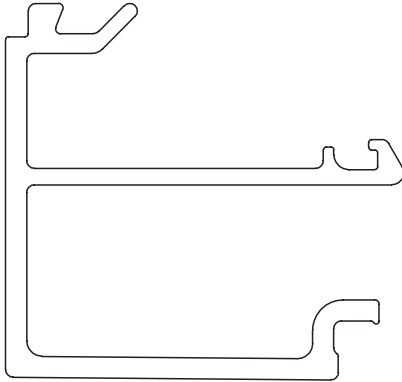

Glass strip ID no. 167257

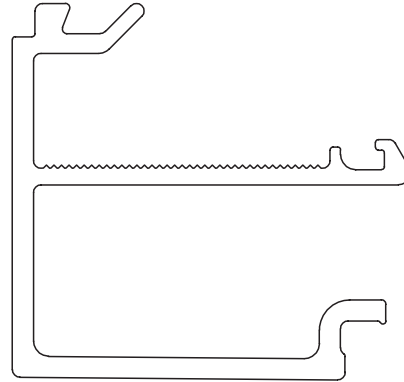

Glass strip ID no. 167258

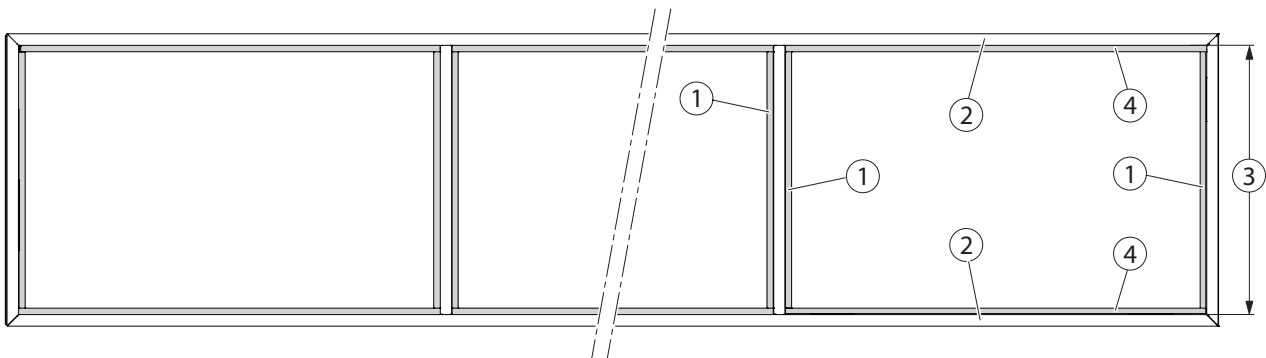

- ▶ Determine the length of the vertical glass strips (1):
  - Clear inner dimension (3) from frame profile to frame profile (2) – 2 × width glass strip visible profile – clearance = Clear inner dimension (3) – 2 × 22 mm = length of the vertical glass strips
- ▶ Measure the length of the horizontal glass strips (4).
- ▶ Cut the glass strips to size.
- ▶ Prepare for final installation.



## 6.2.2 Inserting glass bridges

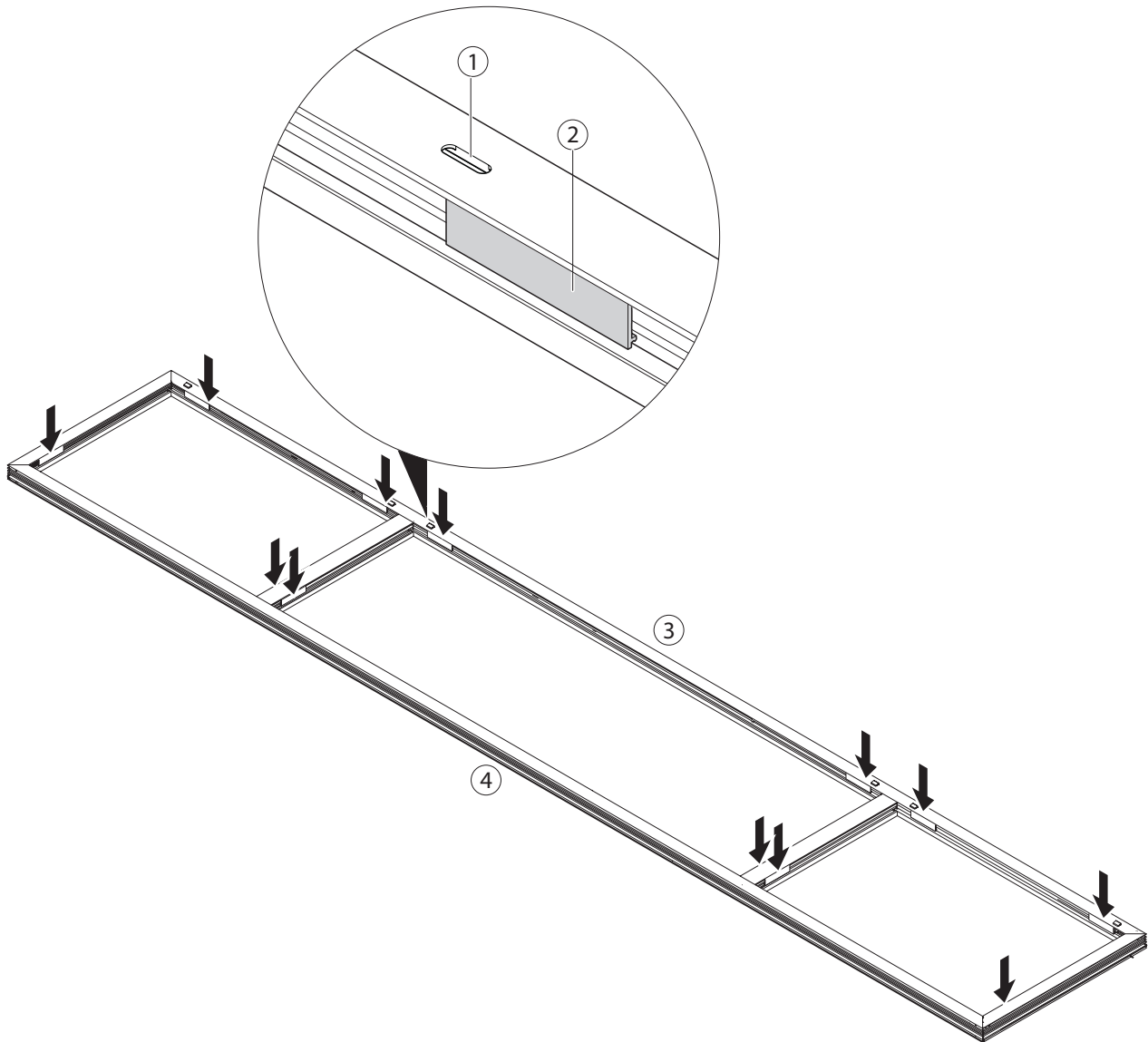

- 1 Water-draining slots
- 2 Glass bridges
- 3 Bottom frame profile
- 4 Top frame profile

- ▶ Clip the glass bridges (2) to the following points (see arrows) in accordance with the fanlight drawing:
  - in the bottom frame profile,
  - vertical frame profiles,
  - in the muntin profiles on the inside (if necessary).



The bottom frame profile (3) can be identified on account of the water-draining slots (1).

### 6.2.3 Drawing in the outer glazing profile



- In the case of a divided fanlight, start at the upper muntin corners.
- In the case of an undivided fanlight, start at any upper corner.

- ▶ Press the outer glazing profile (1) into the inside of the frame and glue in place. The seal must not be under tension when installed.

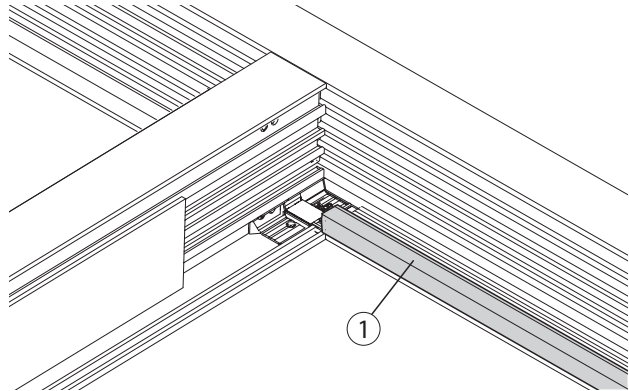

- ▶ At the other edges, cut half-way into the glazing profile using the seal cutting shears.
- ▶ Draw the glazing profile into the corner.
- ▶ Compress the seal slightly. Do not use tension.

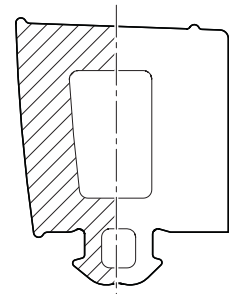

#### Setting up an end joint

- ▶ Cut the glazing profile to the right length.
- ▶ Wet the interface with EPDM adhesive.
- ▶ Draw the glazing profile in and connect using a butt joint.
- ▶ Wipe any excess adhesive off.

## 6.2.4 Inserting glass strips

- ! ▫ During installation of the glass strips make sure that the surfaces of the profile strips are not damaged.

- i ▶ The inner glazing profile rubber (plug-on seal) is supplied separately, not already installed.

- ▶ Clip all the glass strips which have been cut to size (see Chapter 6.2.1) in the following order:
  - horizontal glass strips (1) at the top and bottom frame profile (A)
  - vertical glass strips (2) (B)

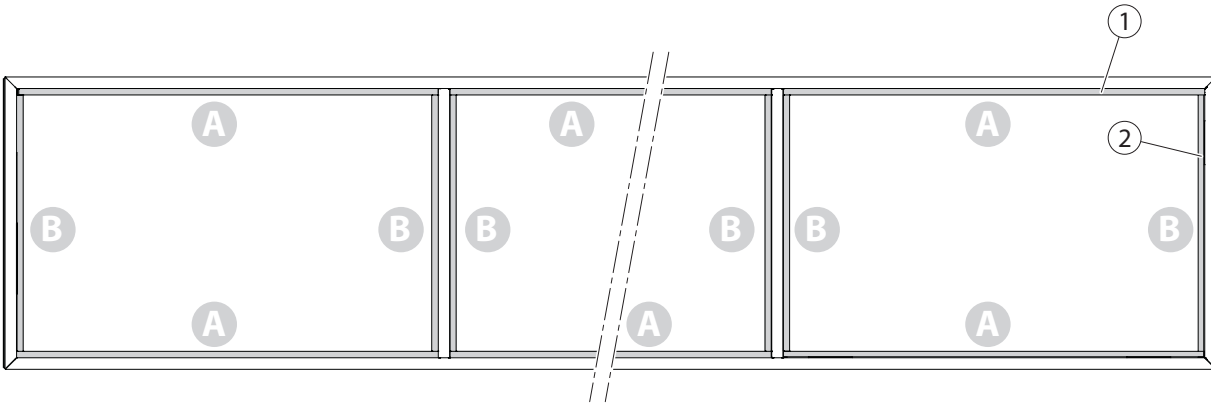

## 6.2.5 Final work

- ▶ Clean the installed frame completely, turn the frame if necessary.
- ▶ Check the installation work:
  - Width and height of the fanlight in accordance with manufacturing order
  - Fanlight muntin positions in accordance with manufacturing order
  - Perpendicular installation using brackets and corner dimension measurement
  - Clearances at profile joints visually
  - Correct installation of all parts in accordance with installation instructions and manufacturing order/bill of material
  - Frame parts not damaged
  - Surface undamaged
  - Frame cleaned
  - Remaining parts included in the packaging in accordance with the bill of material

## 7 Installation on site

### 7.1 Removing the glass strips

- ▶ Remove the glass strips in the opposite order to that described in Chapter 6.2.4.

### 7.2 Preparing the girder section

- ▶ Clip the spacers (1) into the inner groove of the girder section at a distance of 500 mm apart.
- ▶ Fit and insert the seal for the girder section fanlight (2) on the inside between the spacers.
- ▶ Insert the seal for the girder section fanlight (2) continuously on the outside.

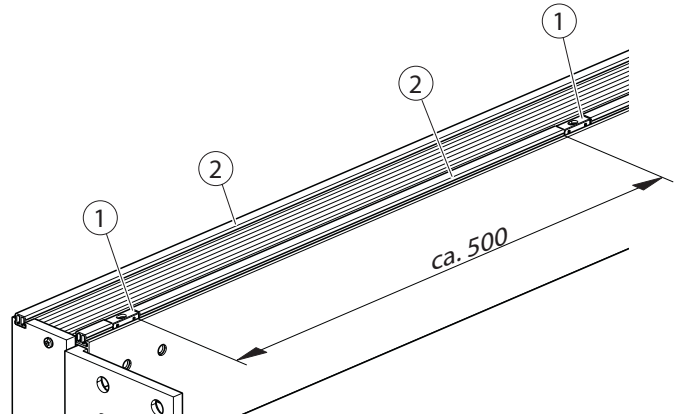

### 7.3 Fixing the fanlight in place

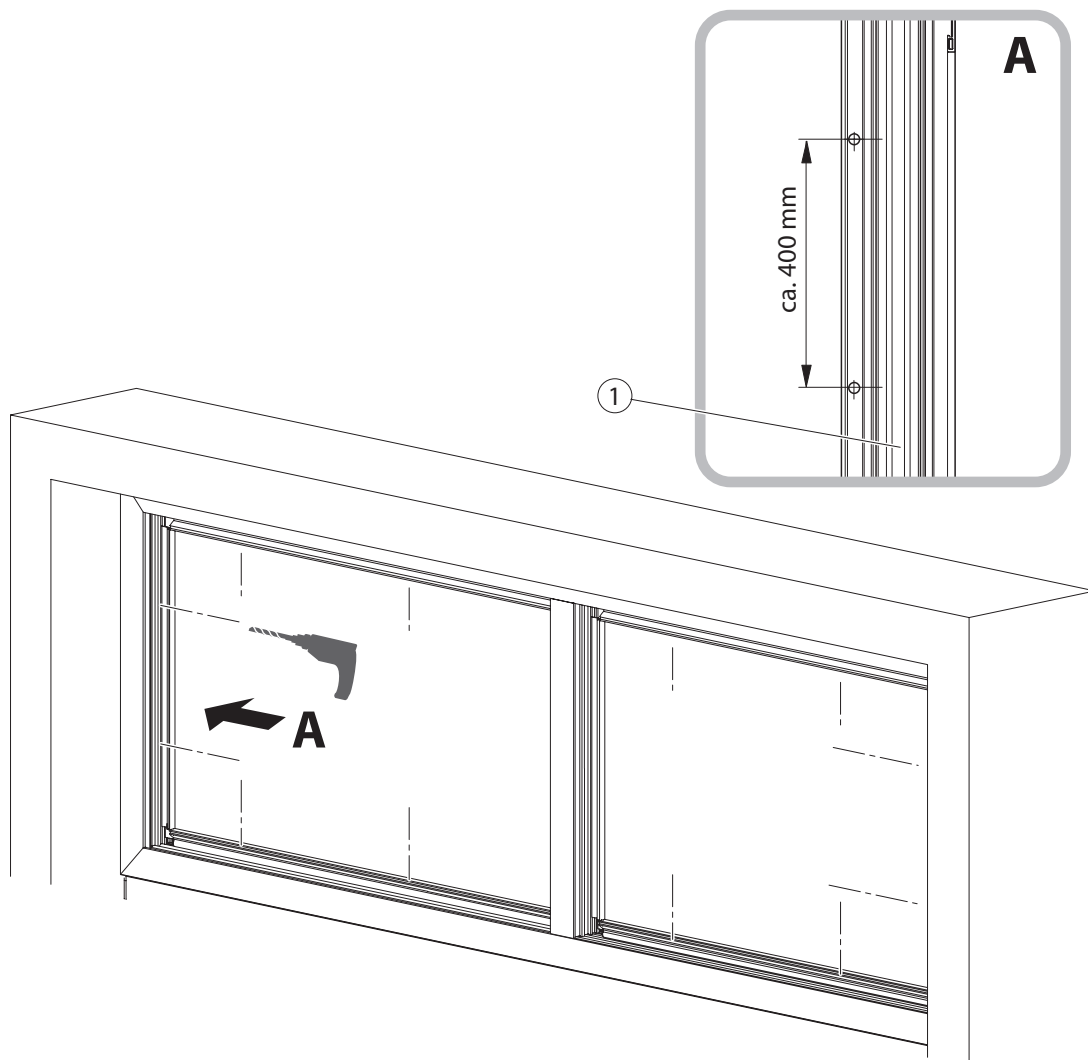

- ▶ Pre-drill holes for window screws in the inner groove (1) of the fanlight frame to the wall, ceiling and girder section at a distance of 400 mm apart.
- ▶ Screw window screws through the profile, wall, ceiling and girder section.

### 7.3.1 Inserting the draining caps

- ▶ Clip draining caps (1) in place on bottom of the fanlight frame.

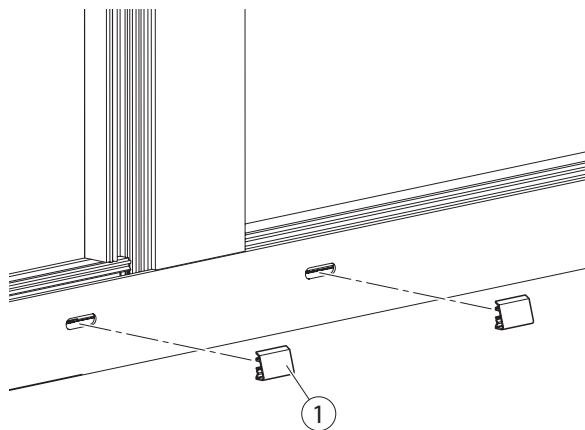

### 7.3.2 Inserting glass

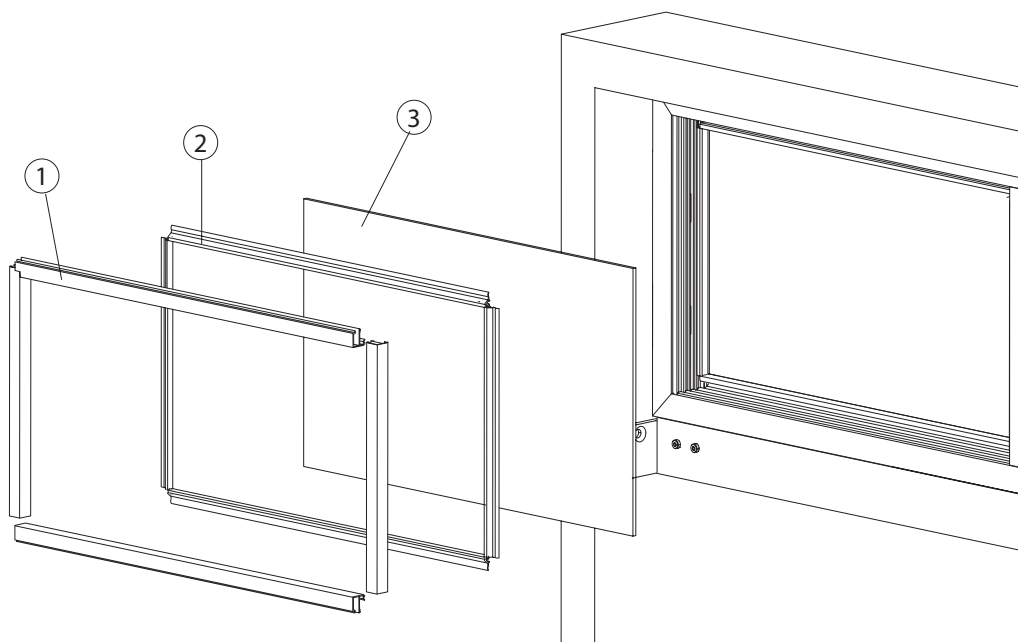

- ▶ Saw the glass strips (1) to size.
- ▶ Insert and block the glass (3).
- ▶ Insert the glass strips (1).
- ▶ Cut the plug-on seals (2) to size and insert.

### 7.4 Final work

- ▶ Carry out the connection to the structure in accordance with RAL-Gütegemeinschaft Fenster und Haustüren e.V. (refer also to Chapter 2.5).
- ▶ Clean the system and the glass surfaces.

## 7.5 Replacing glass panes

(see the picture in Chapter 7.3.2)

- ▶ Remove the plug-on seals (2).
- ▶ Tilt the glass strips (1) towards the glass (3) and remove them.
- ▶ Secure the glass pane to prevent it falling out.
- ▶ Remove the glass (3).
- ▶ Remove the blocks.
- ▶ Insert and block the new glass (see Chapter 7.3.2).
- ▶ Insert the glass strips (1) and plug-on seals (2).

## 8 Cleaning

What is to be cleaned	How is it to be cleaned
Glass surfaces	Wipe with a cold vinegar/water mixture; then dry.
Stainless surfaces	Wipe with non-scratching cloth.
Coated surfaces	Wipe with water and soap.
Anodised surfaces	Wipe with non-alkaline potassium soap (pH value 5.5...7).
Plastic surfaces	Wipe down with water and a mild detergent.
EPDM seals	Wipe down with water and a mild detergent.

## 9 Disassembly

Dismantling is done in reverse order to installation.



**Germany**  
GEZE GmbH  
Niederlassung Süd-West  
Tel. +49 (0) 7152 203 594  
E-Mail: leonberg.de@geze.com

GEZE GmbH  
Niederlassung Süd-Ost  
Tel. +49 (0) 7152 203 6440  
E-Mail: muenchen.de@geze.com

GEZE GmbH  
Niederlassung Ost  
Tel. +49 (0) 7152 203 6840  
E-Mail: berlin.de@geze.com

GEZE GmbH  
Niederlassung Mitte/Luxemburg  
Tel. +49 (0) 7152 203 6888  
E-Mail: frankfurt.de@geze.com

GEZE GmbH  
Niederlassung West  
Tel. +49 (0) 7152 203 6770  
E-Mail: duesseldorf.de@geze.com

GEZE GmbH  
Niederlassung Nord  
Tel. +49 (0) 7152 203 6600  
E-Mail: hamburg.de@geze.com

GEZE Service GmbH  
Tel. +49 (0) 1802 923392  
E-Mail: service-info.de@geze.com

GEZE Industries (Tianjin) Co., Ltd.  
Branch Office Beijing  
E-Mail: chinasaales@geze.com.cn  
www.geze.com.cn

**Austria**  
GEZE Austria  
E-Mail: austria.at@geze.com  
www.geze.at

**Baltic States**  
GEZE GmbH Baltic States office  
E-Mail: office-latvia@geze.com  
www.geze.com

**Benelux**  
GEZE Benelux B.V.  
E-Mail: benelux.nl@geze.com  
www.geze.be  
www.geze.nl

**Bulgaria**  
GEZE Bulgaria - Trade  
E-Mail: office-bulgaria@geze.com  
www.geze.bg

**China**  
GEZE Industries (Tianjin) Co., Ltd.  
E-Mail: chinasaales@geze.com.cn  
www.geze.com.cn

GEZE Industries (Tianjin) Co., Ltd.  
Branch Office Shanghai  
E-Mail: chinasaales@geze.com.cn  
www.geze.com.cn

GEZE Industries (Tianjin) Co., Ltd.  
Branch Office Guangzhou  
E-Mail: chinasaales@geze.com.cn  
www.geze.com.cn

GEZE Industries (Tianjin) Co., Ltd.  
Branch Office Beijing  
E-Mail: chinasaales@geze.com.cn  
www.geze.com.cn

**France**  
GEZE France S.A.R.L.  
E-Mail: france.fr@geze.com  
www.geze.fr

**Hungary**  
GEZE Hungary Kft.  
E-Mail: office-hungary@geze.com  
www.geze.hu

**Iberia**  
GEZE Iberia S.R.L.  
E-Mail: info@geze.es  
www.geze.es

**India**  
GEZE India Private Ltd.  
E-Mail: office-india@geze.com  
www.geze.in

**Italy**  
GEZE Italia S.r.l  
E-Mail: italia.it@geze.com  
www.geze.it

GEZE Engineering Roma S.r.l  
E-Mail: roma@geze.biz  
www.geze.it

**Poland**  
GEZE Polska Sp.z o.o.  
E-Mail: geze.pl@geze.com  
www.geze.pl

**Romania**  
GEZE Romania S.R.L.  
E-Mail: office-romania@geze.com  
www.geze.ro

**Russia**  
OOO GEZE RUS  
E-Mail: office-russia@geze.com  
www.geze.ru

**Scandinavia – Sweden**  
GEZE Scandinavia AB  
E-Mail: sverige.se@geze.com  
www.geze.se

**Scandinavia – Norway**  
GEZE Scandinavia AB avd. Norge  
E-Mail: norge.se@geze.com  
www.geze.no

**Scandinavia – Denmark**  
GEZE Danmark  
E-Mail: danmark.se@geze.com  
www.geze.dk

**Singapore**  
GEZE (Asia Pacific) Pte, Ltd.  
E-Mail: gezesea@geze.com.sg  
www.geze.com

**South Africa**  
GEZE South Africa (Pty) Ltd.  
E-Mail: info@gezesa.co.za  
www.geze.co.za

**Switzerland**  
GEZE Schweiz AG  
E-Mail: schweiz.ch@geze.com  
www.geze.ch

**Turkey**  
GEZE Kapı ve Pencere Sistemleri  
E-Mail: office-turkey@geze.com  
www.geze.com

**Ukraine**  
LLC GEZE Ukraine  
E-Mail: office-ukraine@geze.com  
www.geze.ua

**United Arab Emirates/GCC**  
GEZE Middle East  
E-Mail: gezeme@geze.com  
www.geze.ae

**United Kingdom**  
GEZE UK Ltd.  
E-Mail: info.uk@geze.com  
www.geze.com

**GEZE GmbH**  
Reinhold-Vöster-Straße 21–29  
71229 Leonberg  
Germany

Tel.: 0049 7152 203 0  
Fax.: 0049 7152 203 310  
www.geze.com

